

THIS DRAWING IS UNPUBLISHED. RELEASED FOR PUBLICATION
 © COPYRIGHT BY TYCO ELECTRONICS CORPORATION. ALL RIGHTS RESERVED.

LOC	DIST	REVISIONS					
GP	00	P	LTR	DESCRIPTION	DATE	DWN	APVD
		K3		REVISED PER ECO-07-008164	10AUG07	JDP	CWR

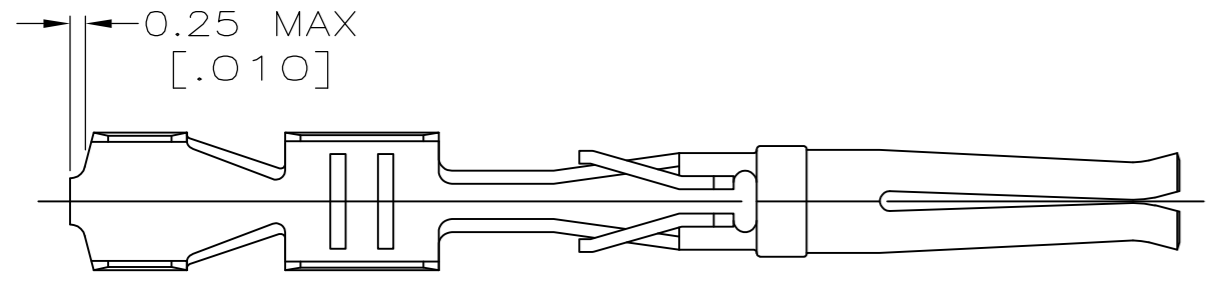

DETAIL Z
SCALE 8:1

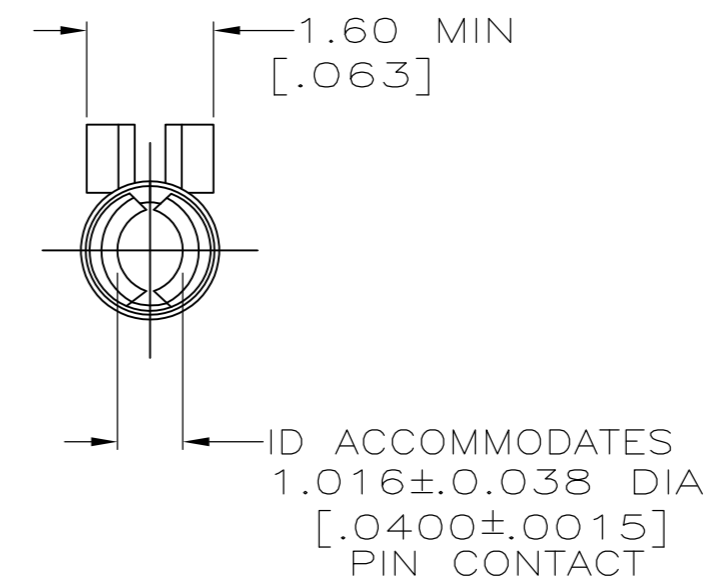
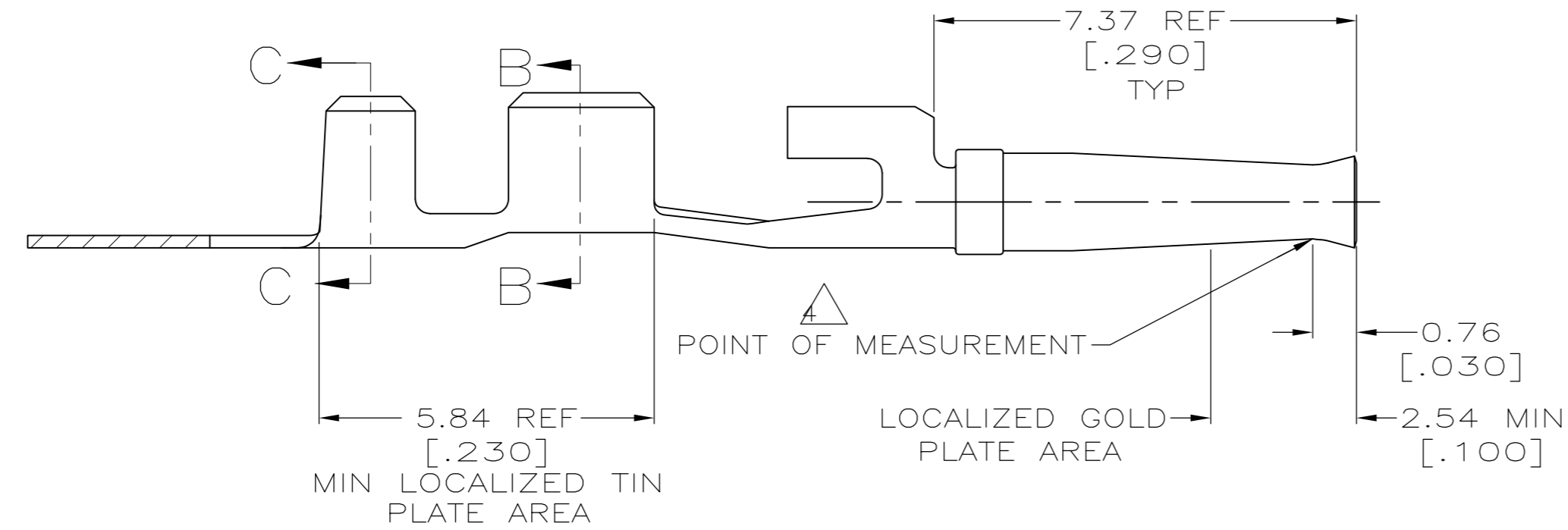
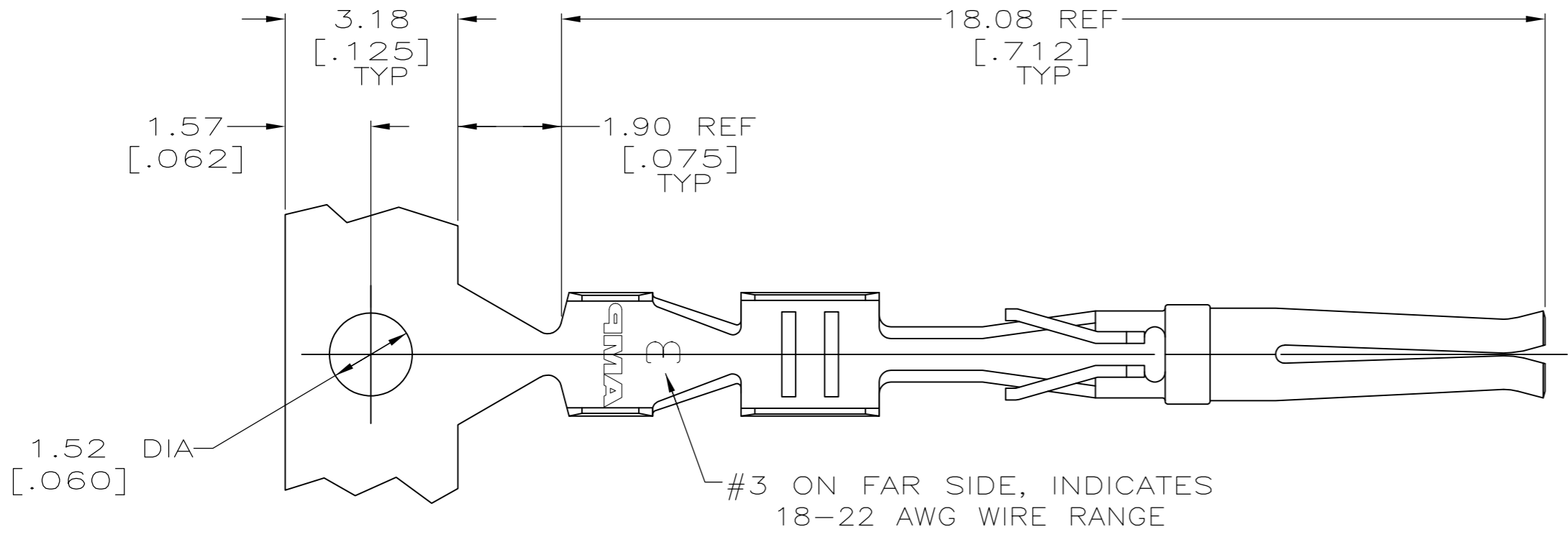

- ① GOLD PLATING PER MIL-G-45204, TIN PLATING PER MIL-T-10727, NICKEL PLATING PER QQ-N-290.
- ② 0.76 μm [.000030] MIN GOLD IN LOCALIZED GOLD PLATE AREA, 2.54 μm [.000100] MIN BRIGHT TIN OR BRIGHT TIN-LEAD IN MIN LOCALIZED TIN PLATE AREA, ALL OVER 0.76 μm [.000030] MIN NICKEL.
- ③ GOLD FLASH IN LOCALIZED GOLD PLATE AREA, 2.54 μm [.000100] MIN BRIGHT TIN OR BRIGHT TIN-LEAD IN MIN LOCALIZED TIN PLATE AREA, ALL OVER 0.76 μm [.000030] MIN NICKEL.
- ④ POINT OF MEASUREMENT FOR GOLD AND NICKEL IS ON THE INSIDE SURFACE FOR NOTE ② AND ⑥ ONLY, AND OUTSIDE SURFACE FOR NOTE ③ AND ⑤.
- ⑤ GOLD FLASH IN LOCALIZED GOLD PLATE AREA, 2.54 μm [.0001] MIN MATTE TIN IN LOCALIZED TIN PLATE AREA, ALL OVER 0.76 μm [.000030] MIN NICKEL UNDERPLATE.
- ⑥ 0.76 μm [.00030] MIN GOLD IN LOCALIZED GOLD PLATE AREA, 2.54 μm [.0001] MIN MATTE TIN IN LOCALIZED TIN PLATE AREA, ALL OVER 1.27 μm [.000050] MIN NICKEL UNDERPLATE.
- ⑦ PHOSPHOR BRONZE PER QQ-B-750.

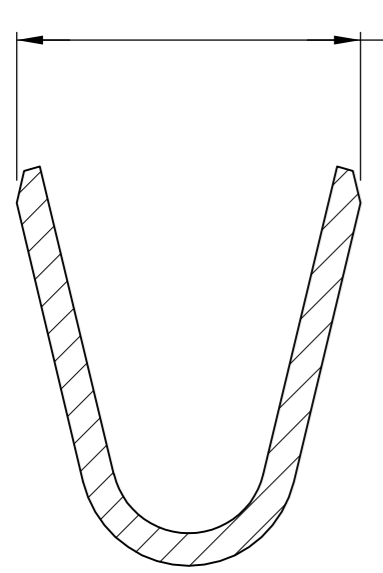

SECTION C-C
SCALE 20:1

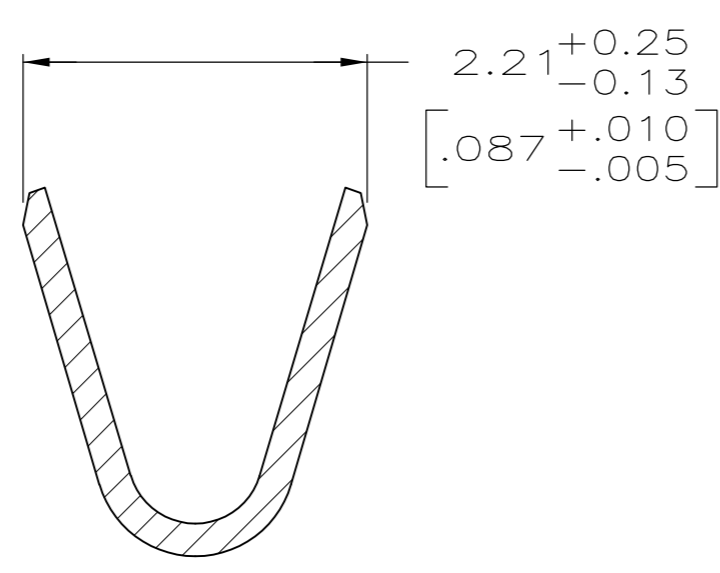

SECTION B-B
SCALE 20:1

REVISION	DESCRIPTION	DATE	BY
⑥	-	11-15-04	L. VARELA - DOCK5
⑤	-	11-15-04	J. GERACE
-	DETAIL Z	11-15-04	M. WALMSLEY
-	DETAIL Z	-	-
③	DETAIL Z	-	-
③	-	-	-
-	DETAIL Z	-	-
-	-	-	-
②	DETAIL Z	-	-
②	-	-	-

THIS DRAWING IS A CONTROLLED DOCUMENT.		DWN 11-15-04 L. VARELA - DOCK5	Tyco Electronics Corporation Harrisburg, PA 17105-3608	
DIMENSIONS: mm [INCHES]	TOLERANCES UNLESS OTHERWISE SPECIFIED:	CHK 11-15-04 J. GERACE	NAME CONTACT SOCKET, OPEN BARREL, #18-22, HDE-20, AMPLIMITE	
	0 PLC ± -	APVD 11-15-04 M. WALMSLEY	PRODUCT SPEC	108-40011
	1 PLC ± -	PRODUCT SPEC	APPLICATION SPEC	114-40003
	2 PLC ± 0.13 [.005]	SIZE	A2	00779
	3 PLC ± -	WEIGHT	-	-
	4 PLC ± -	CAGE CODE	C=745270	SCALE 10:1
	ANGLES ± -	FINISH	SEE TABLE	SHEET 1 OF 1
MATERIAL ⑦	FINISH ①	CUSTOMER DRAWING	REV K3	